

HTS Triax™ Energy Cables – A new intelligent cable concept

Dag Willén
nkt cables

Waldur Symposium
Eindhoven
27 Nov 2007

Outline

- Status of Supercable technology
 - Operation experience
 - HTS Triax™
 - HTS Coax
 - Situation in the grid
- Uses in the grid
 - MV applications – **commercial now!**
 - Advanced MV applications – **large market**
 - HV applications – **mature long-distance transmission**
- Conclusion

New technology? nkt cables has 9 years of operation experience!



- Copenhagen, Denmark
 - 30 m x 2.0 kA x 30 kV
 - 104 MW
 - 2 years operation
 - 12,000 h at 100% load
- Years 2001-2003
- DK utilities
- Supplied 50,000 users
- 2-year long-term test

$\Sigma = 2$ years



Joint venture between nkt cables and Southwire Co.

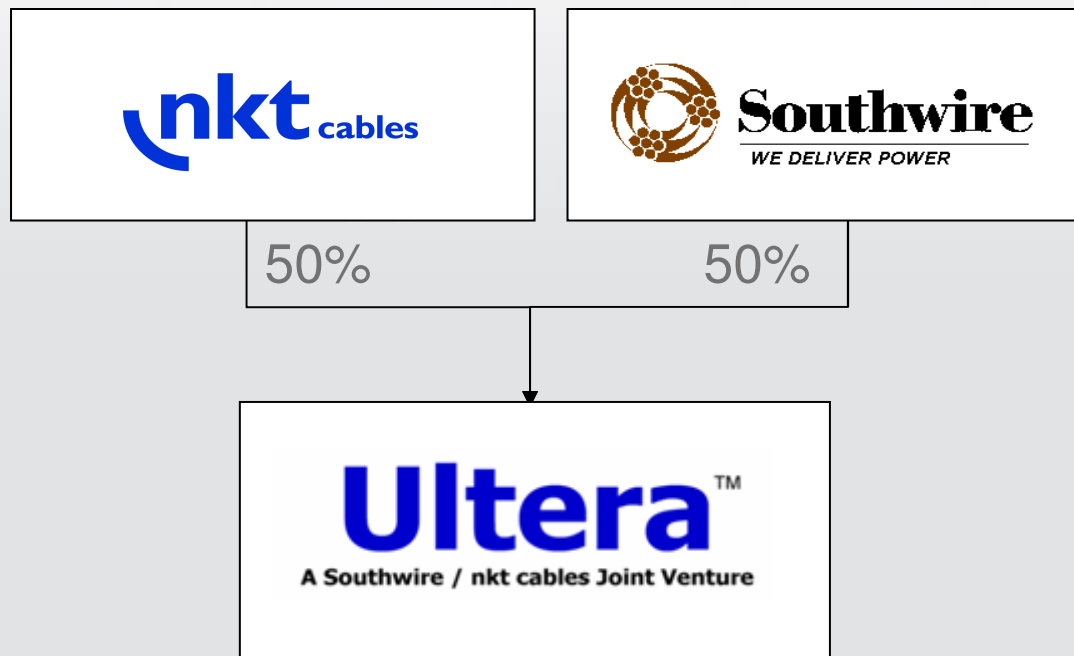

9 years of operation experience: Southwire, Carrollton, Georgia



- Carrollton, U.S.A
 - 30 m x 1.25 kA x 12.5 kV
 - 27 MW
 - **6 years operation**
 - 50,000 h at 100% load
- Years 2000 - 2006
- Supplied energy to Southwire Co's cable factories
- Converted to test station

$\Sigma = 8$ years

Latest experience: HTS Triax™ Energy Cable



- Three phases in one cable
- Common neutral screen
- Cryostat duct (thermal insulation)
- 10-72 kV
- 30-400 MW



Type test successful!



- According to international norms
- AC and DC current to 3400 A
- AC Voltage up to to 39 kV rms
- Lighting impulse testing (BIL) at 110 kV peak

200 m pilot installation running with American Electric Power Co.



- Installed and commissioned 2006
- Operating since 8 Aug 2006
- 13 kV, 69 MW
- First year completed

Terminations

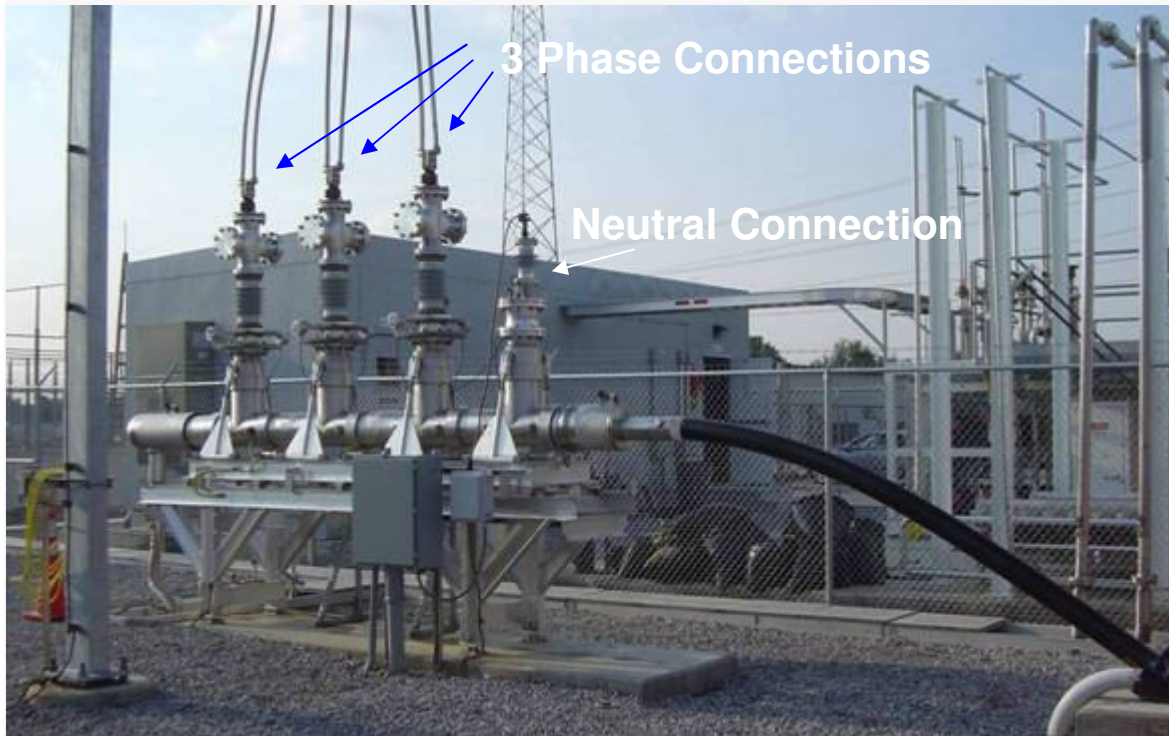

- Three-phase terminations
- Vertical insulators

Splice in underground vault



- Cable was cut in two pieces
- Three-phase splice

First-year operation statistics

- Energized: 8 Aug 2006
- Date: 8 Aug 2007
- Time since start: 8756 h/365 d
- Time in operation: 8752 h/365 d
- Cable outings: 1
 - Service outings: 0
 - Scheduled outings: 1
 - Failures: 0
- Availability: 99.95%
- Min Power: 18 MW
- Max Power: 58 MW
- Ave Power: 30 MW
- Transmitted energy: 264 GWh

$\Sigma = 9$ years

HTS Triax™ Energy Cable

- Suitable for medium voltages (10-72 kV)

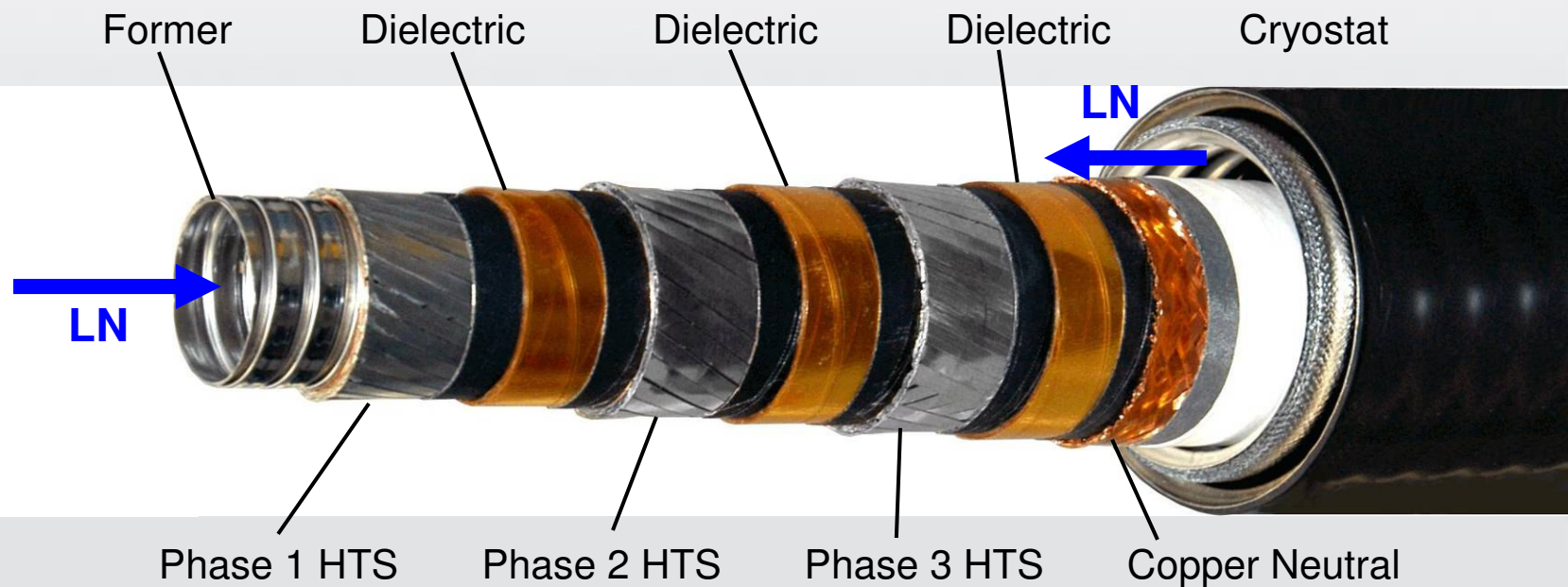

HTS Coax High-Voltage Cables

- Same materials and machinery
- Suitable for higher voltages, 50 - 150 kV

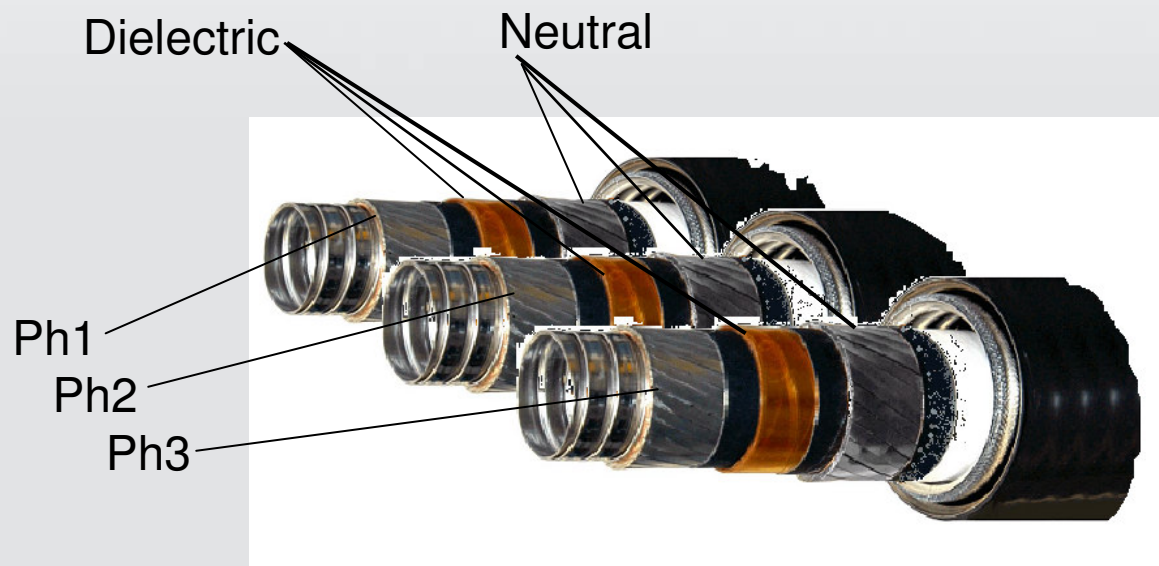

Situation in the grid

- Smarter and more flexible grids
- Renewable and distributed energy
 - Production by wind, solar and bio-fuels
 - Storage in electrical car parks, exchange with hydro
 - Increased focus on strong MV connections
- Invisible grids
 - Less tolerance for overhead
 - Less tolerance for EMF
- Electricity is the dominating energy carrier

HTS Energy Cables are part of the solution!



Example: EMF aspects

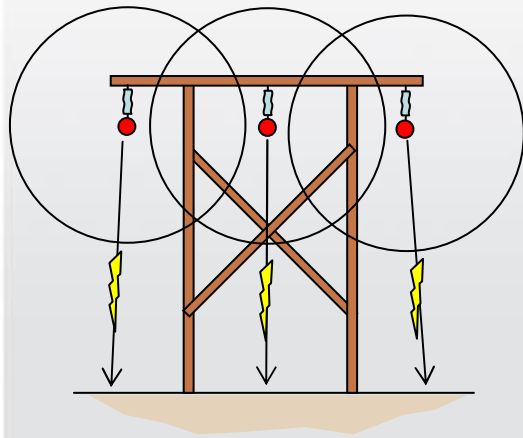

OH

UG - flat

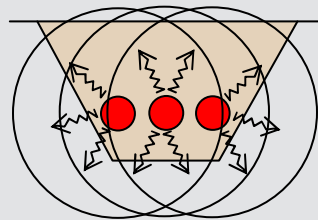

UG - trefoil

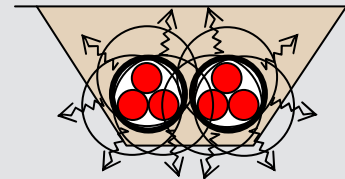

HTS Triax™

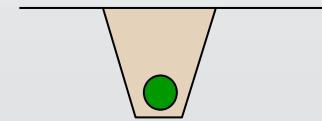

HTS Coax

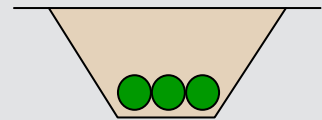

Less EMF, less heat



SUPER GREEN



Uses in the grid

1. MV applications

Now available on a commercial basis!



Replacing HV in dense areas

- One HTS Triax™ Energy Cable can replace
 - Three HV cables
 - A HV transformer station
- Re-location of HV transformer stations
 - Outside city centers
 - Away from generation facilities

Increased flexibility for the planner

Example: AEP Columbus, Ohio

- The full station load is transported in one HTS Triax™ Energy Cable
- This demonstrates the case:

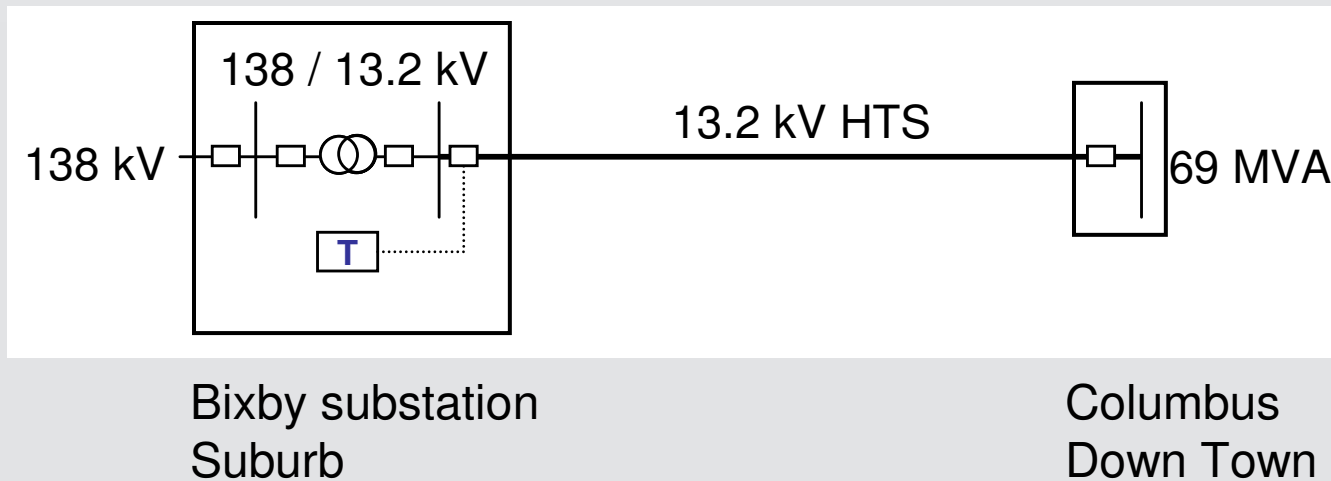

Example: 1700 m in New Orleans

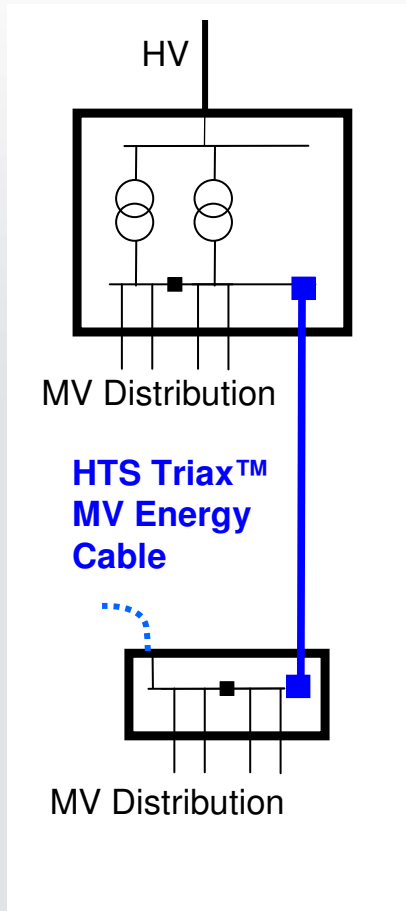

- 13 kV HTS Triax™
- 64 MVA
- Replaces a 220 kV line and the HV section of a transformer substation



- Fewer HV transformers
- Fewer HV breakers
- Less construction



Uses in the grid

2. Advanced MV applications

Requires 2-3 years more development



New functionality

- 2nd generation HTS conductors
- Use the natural VI curve

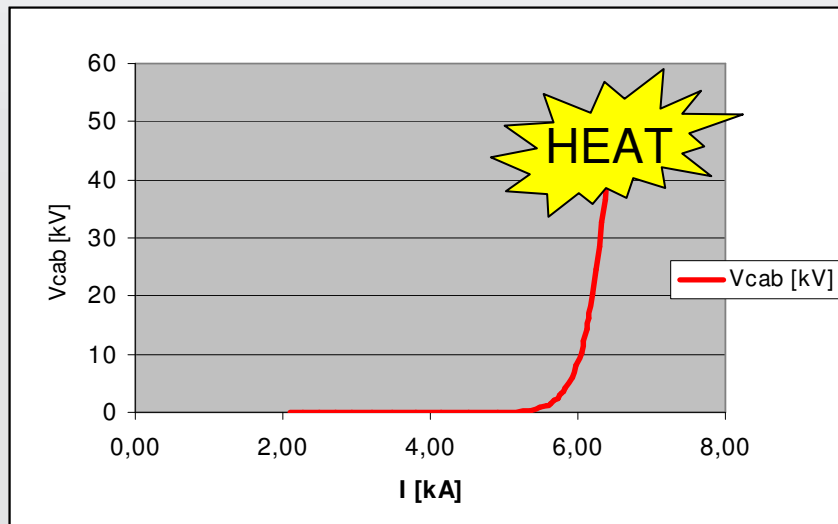

- Thermal management
- ⇒ Fault-Current Limitation (FCL)

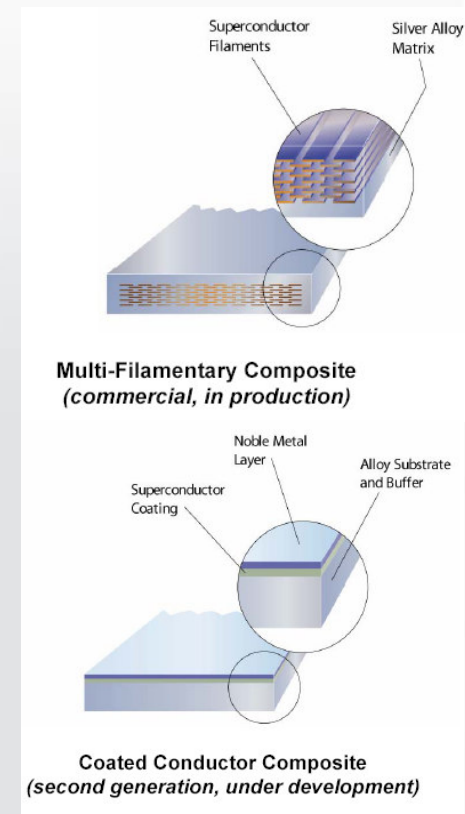

American Superconductor Corp.
<http://www.amsuper.com>

”Secure Super Grids™”

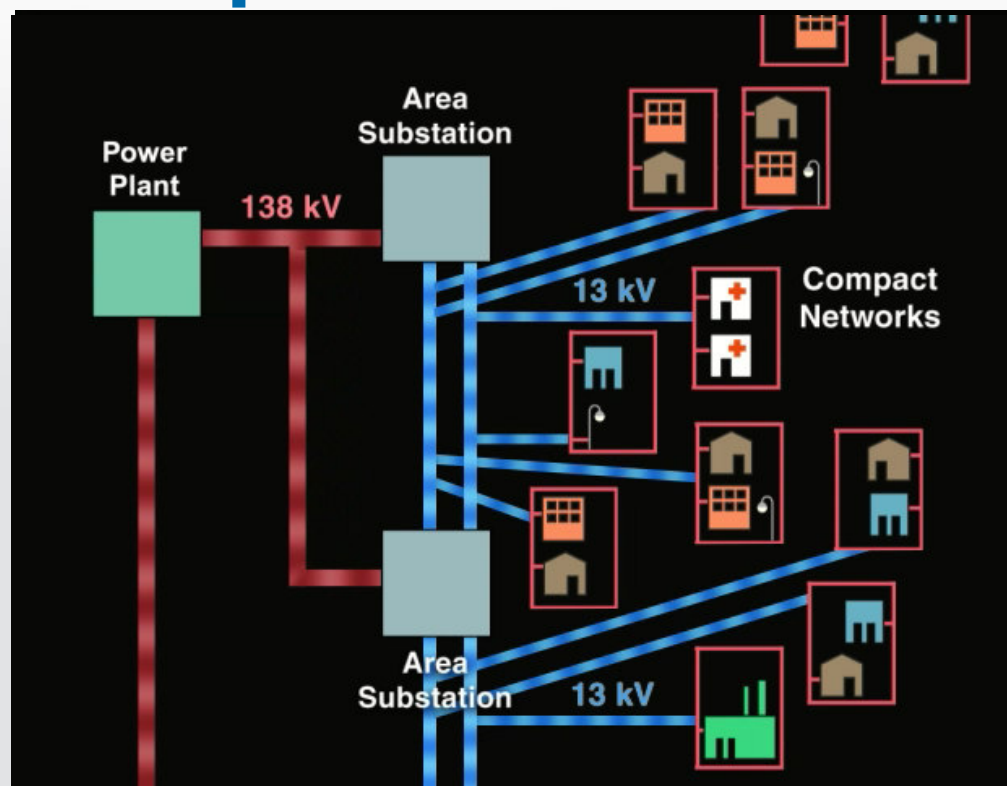

- Increased meshing on MV side
- Reduced size of the supply loops



Completing the picture

Example: 13 kV HTS Triax™ FCL

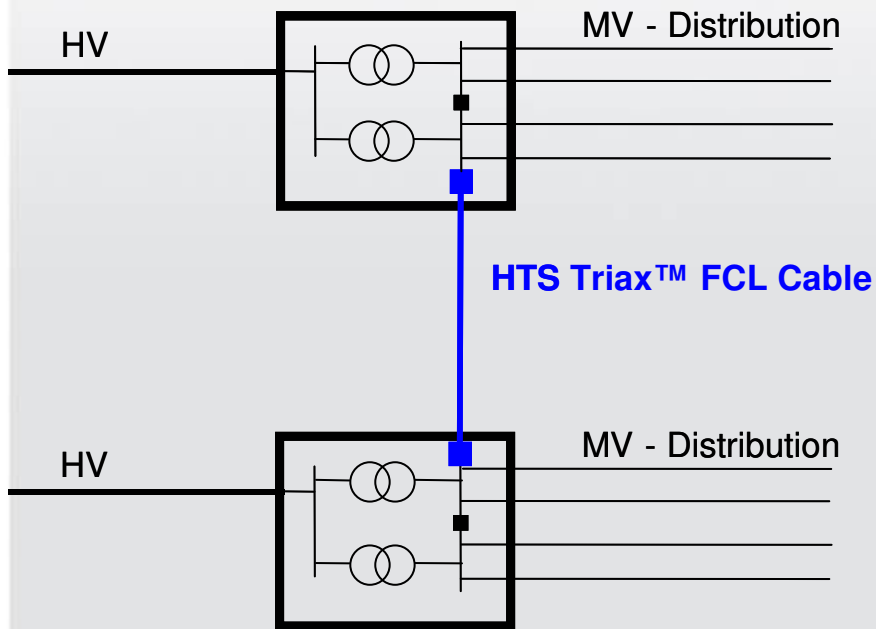

New York City Station-to-Station Tie on Low Side of Transformers

- Carry full station load at MV
- Share transformer redundancy between distribution stations
- Increase transformer asset utilization

Increased reliability and resilience

Example: 6 km in Amsterdam

- Presentation by Alex Geschiere, NUON
 - Real challenge
 - Opens the door to widespread use of HTS technology

Voltage rating now at 35 kV
Need upgrade to 50 kV

New cooling machinery
Deployed in Columbus, OH

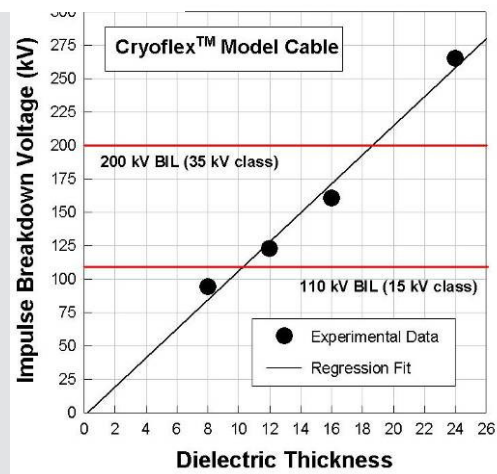

Example: 6 km in Amsterdam

- Reduced cryostat heat loss
- Reduced AC loss

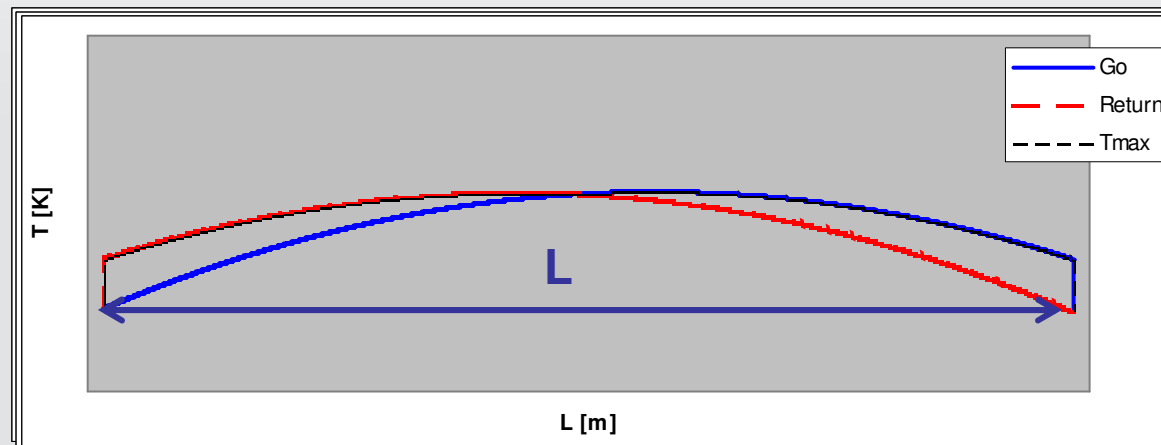

Longer length possible

Uses in the grid

3. HV Transmission

Requires maturity and lower cost



Cost aspect – HTS conductor

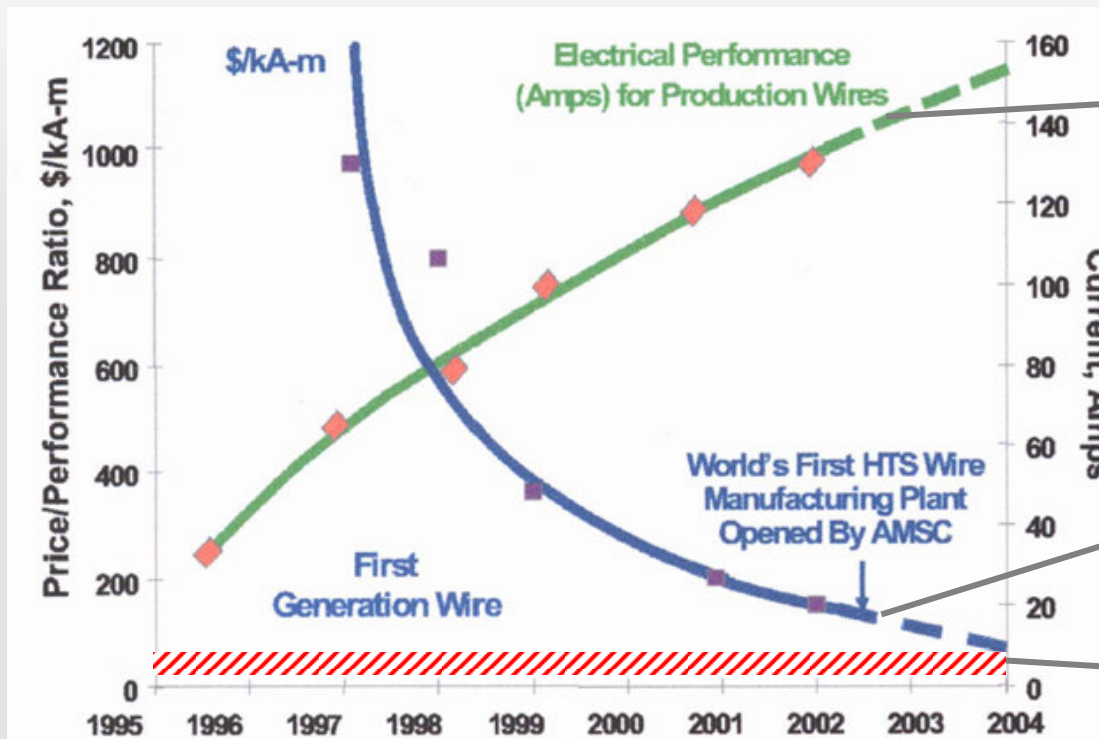

Increased performance

Cost is approaching copper

Cost aspect - System

+ More expensive

- + Cable
- + Accessories
- + Cooler

- Less expensive

- Permits
- Civil works
- Installation
- Breakers
- Transformers
- Converters
- Reactive power compensation

Case-by-case evaluation



Cost – lower than copper ?

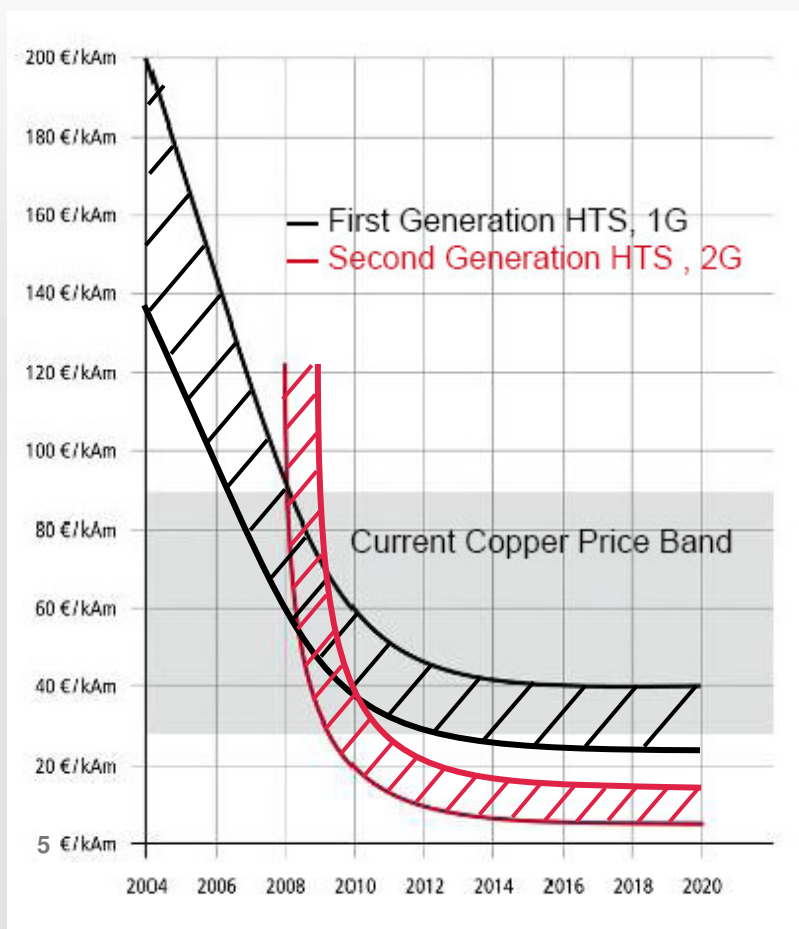

Second generation:

Crossover
with 1-G in
2008-2009 ?

Eventually
lower cost
than copper due
to 2-G tapes

**Long-length
transmission may
become possible**

Challenges for Transmission

- To get right-of-way for overhead lines
 - Visibility, noise, EMF
- 380-420 kV underground PEX/AL/CU
 - High connection costs
 - Expensive phase compensation
- HVDC
 - Expensive converter stations
 - No meshing

Solution

- 110-150 kV/800-1000 MVA HTS
 - Low impedance
 - Behaves similarly to OH line
 - Low connection costs
 - Save on phase compensation

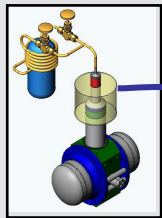

Transmission length

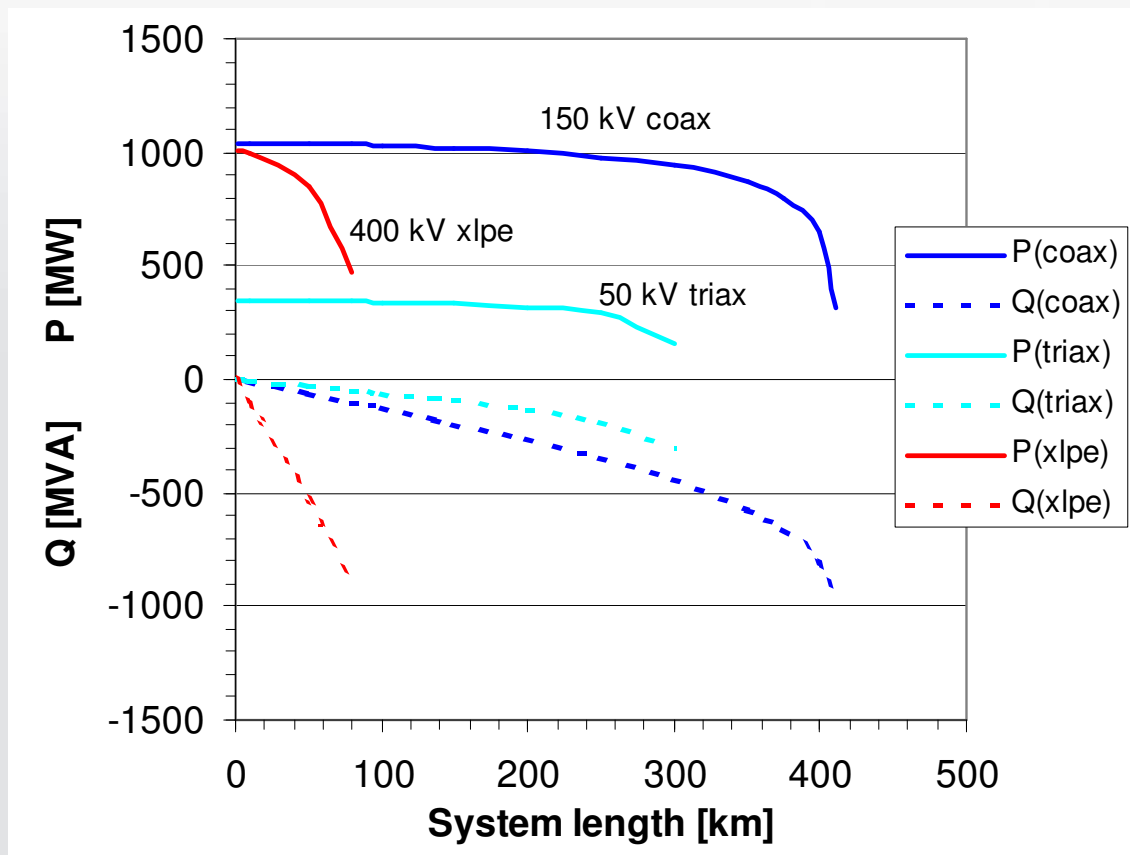

Example: 150 km, 2 GVA

- Alt 1: 400 kV OH + UG
 - Reactive power
 - Stability
 - Visibility

- Alt 2: HVDC
 - Expensive converters
 - Difficult to connect underway
 - Need parallel AC system

- Alt 3: HV HTS Energy Cable
 - Invisible & efficient
 - Serves the local communities
 - **Super green**

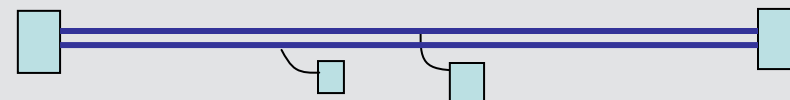
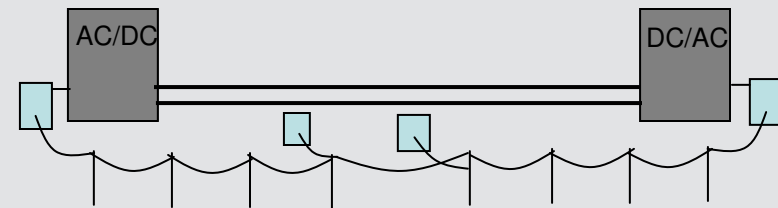
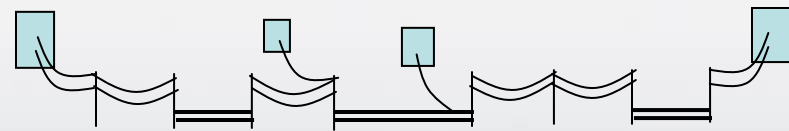

Conclusion

1. First commercial product available
 - MV HTS Triax™ Energy Cable, e.g. Columbus, OH
 - Uses in high-power-density areas, e.g. New Orleans

2. Improved properties and functionality
 - HTS Triax™ FCL cable, e.g. New York
 - Longer systems, e.g. Amsterdam
 - Opens the door for widespread use

3. Great potential in transmission
 - 500 – 1000 MVA at 110-150 kV
 - Long critical lengths
 - Easy connection

**Need the opportunity to
prove the potential!**

Thank You!



Completing the picture